

# Technical Specification

## Hydraulic crane

### PK 12502 SH

(S106-SK-D)

---

Edition 06/2012

EN

---

PALFINGER AG  
Lamprechtshausener Bundesstraße 8  
5101 Bergheim / Austria  
[www.palfinger.com](http://www.palfinger.com)

Page	
<b>020</b>	<b>LIFTING CAPACITY DIAGRAM</b>
020.01100	Lifting capacity diagram PK 12502-SH ()
020.02100	Lifting capacity diagram PK 12502 SH A
020.03100	Lifting capacity diagram PK 12502-SH B
020.04100	Lifting capacity diagram PK 12502-SH C
020.05100	Lifting capacity diagram PK 12502-SH D
020.21100	Load capacity-Extension
020.21200	Load capacity-Rope winch 1.5t
020.31100	Working area FPM PK 12502-SH D

Subject to change, production tolerances have to be taken into account.

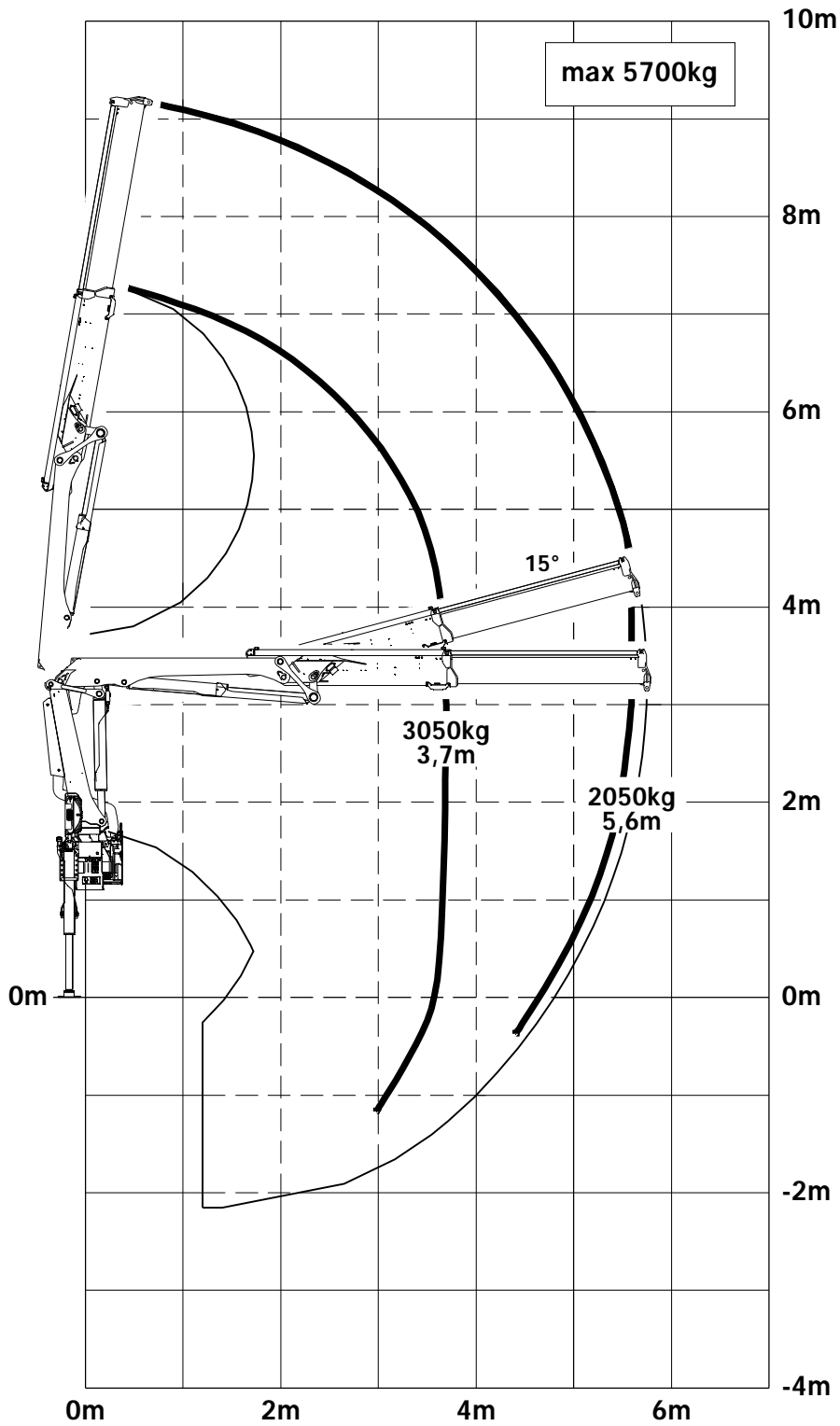

Symbolic crane figure, indications at 20° main boom position & load arm in horizontal position



For Rope winch load capacity refer to page  
Page 020.21200

Lifting capacity diagram PK 12502 SH A

Subject to change, production tolerances have to be taken into account.

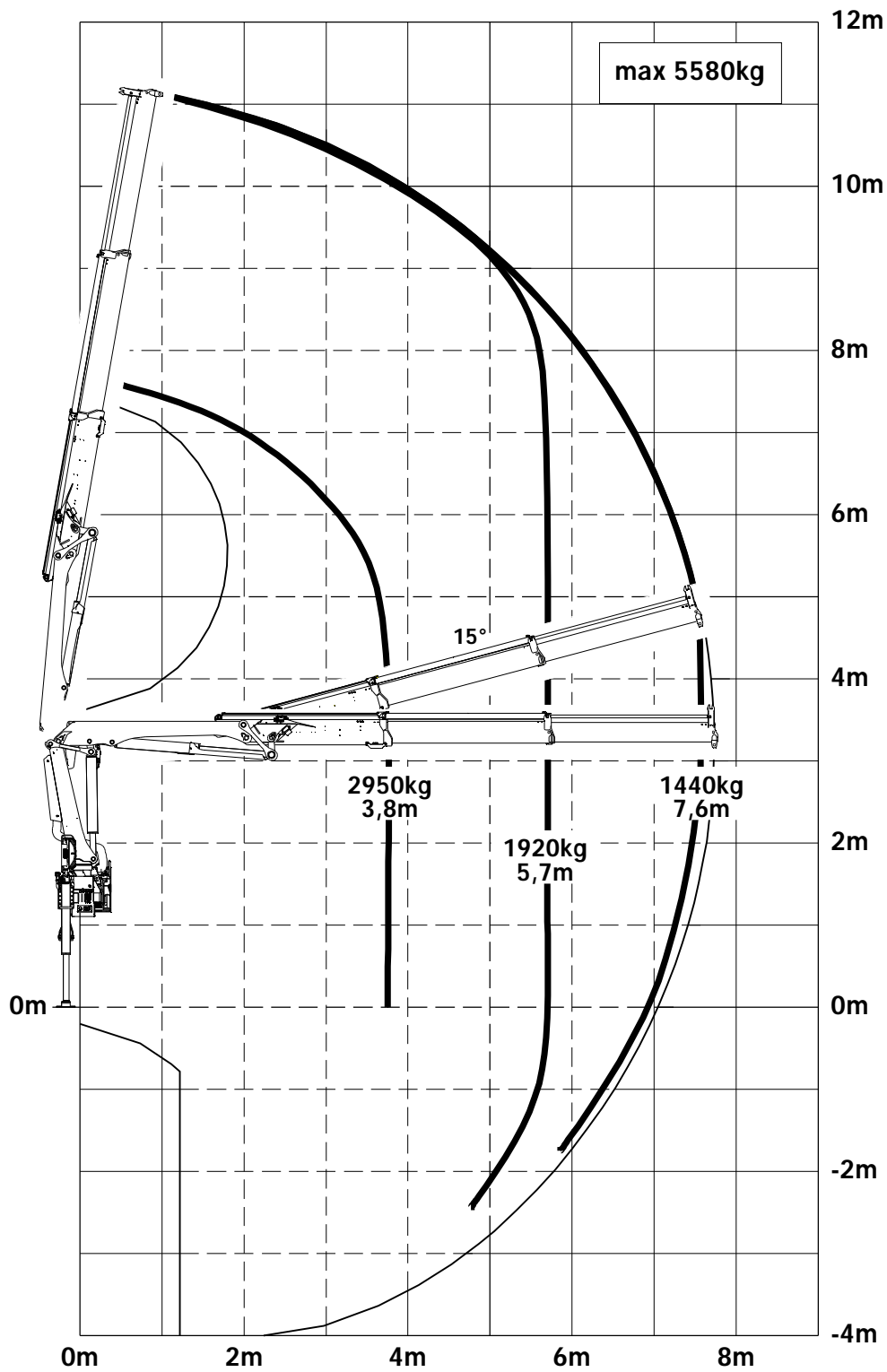

Symbolic crane figure, indications at 20° main boom position & load arm in horizontal position



For Rope winch load capacity refer to page  
Page 020.21200

Subject to change, production tolerances have to be taken into account.

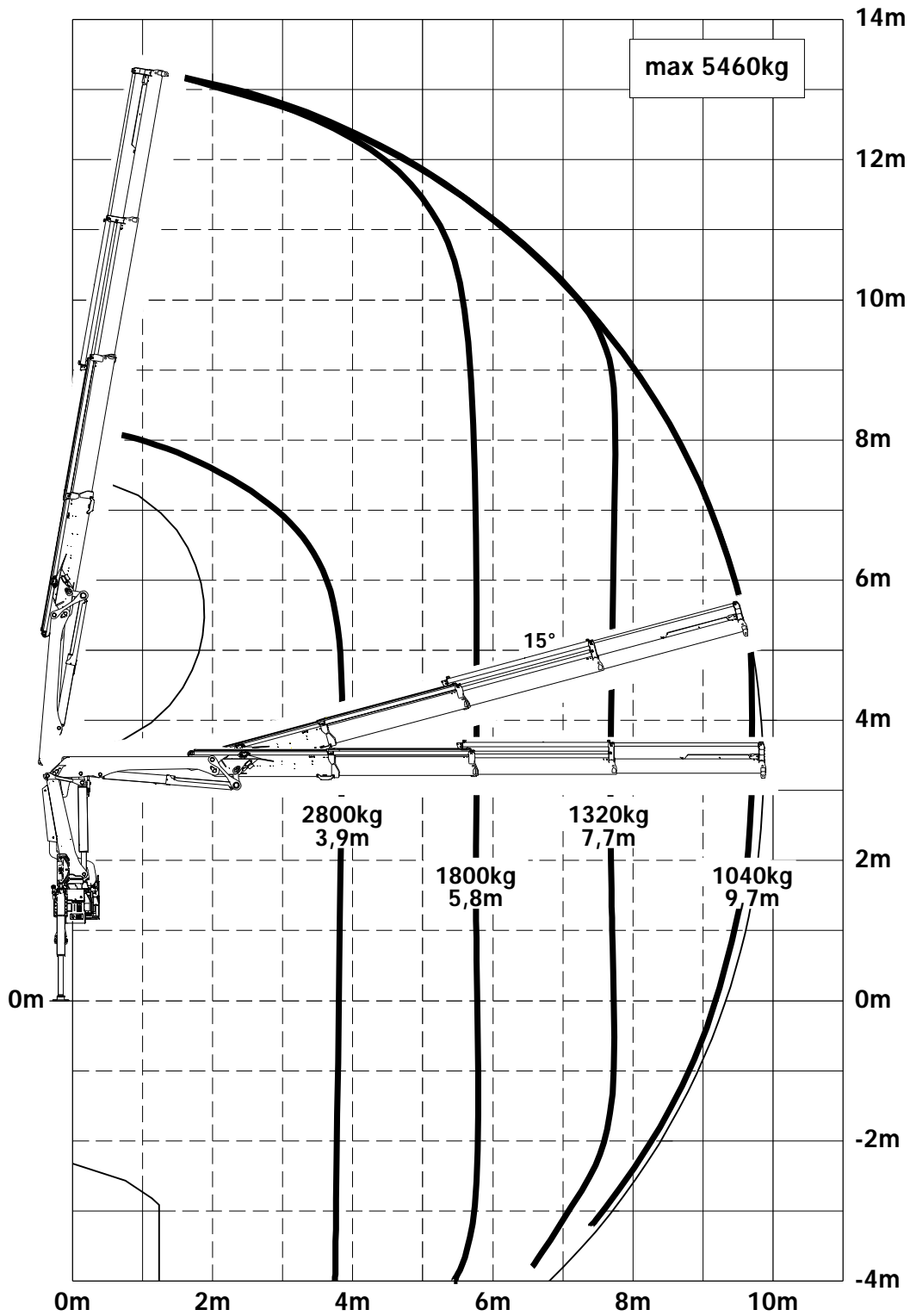

Symbolic crane figure, indications at 20° main boom position & load arm in horizontal position



For Rope winch load capacity refer to page  
Page 020.21200

Lifting capacity diagram PK 12502-SH C

Subject to change, production tolerances have to be taken into account.

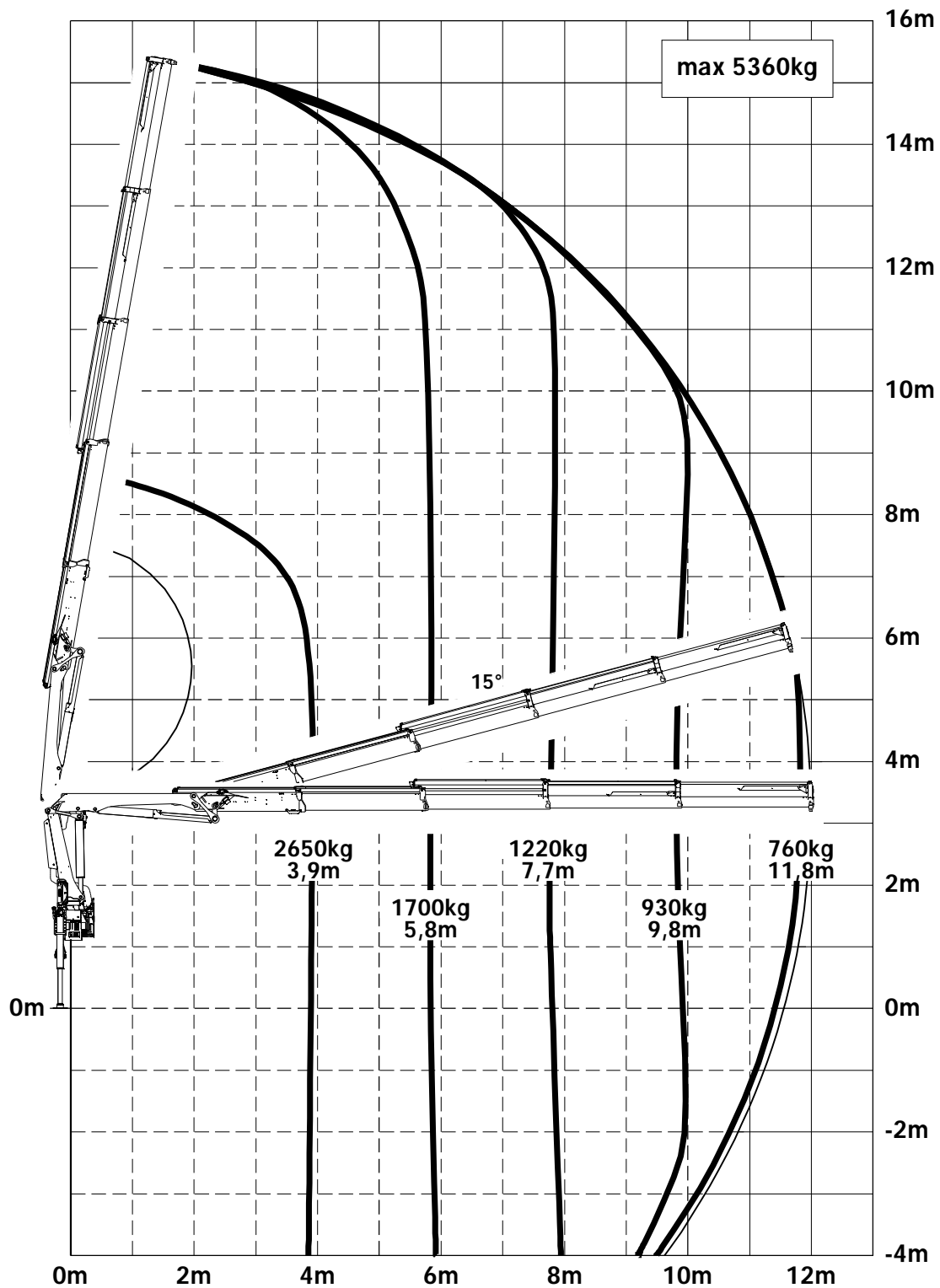

Symbolic crane figure, indications at 20° main boom position & load arm in horizontal position



For Rope winch load capacity refer to page  
Page 020.21200

Subject to change, production tolerances have to be taken into account.

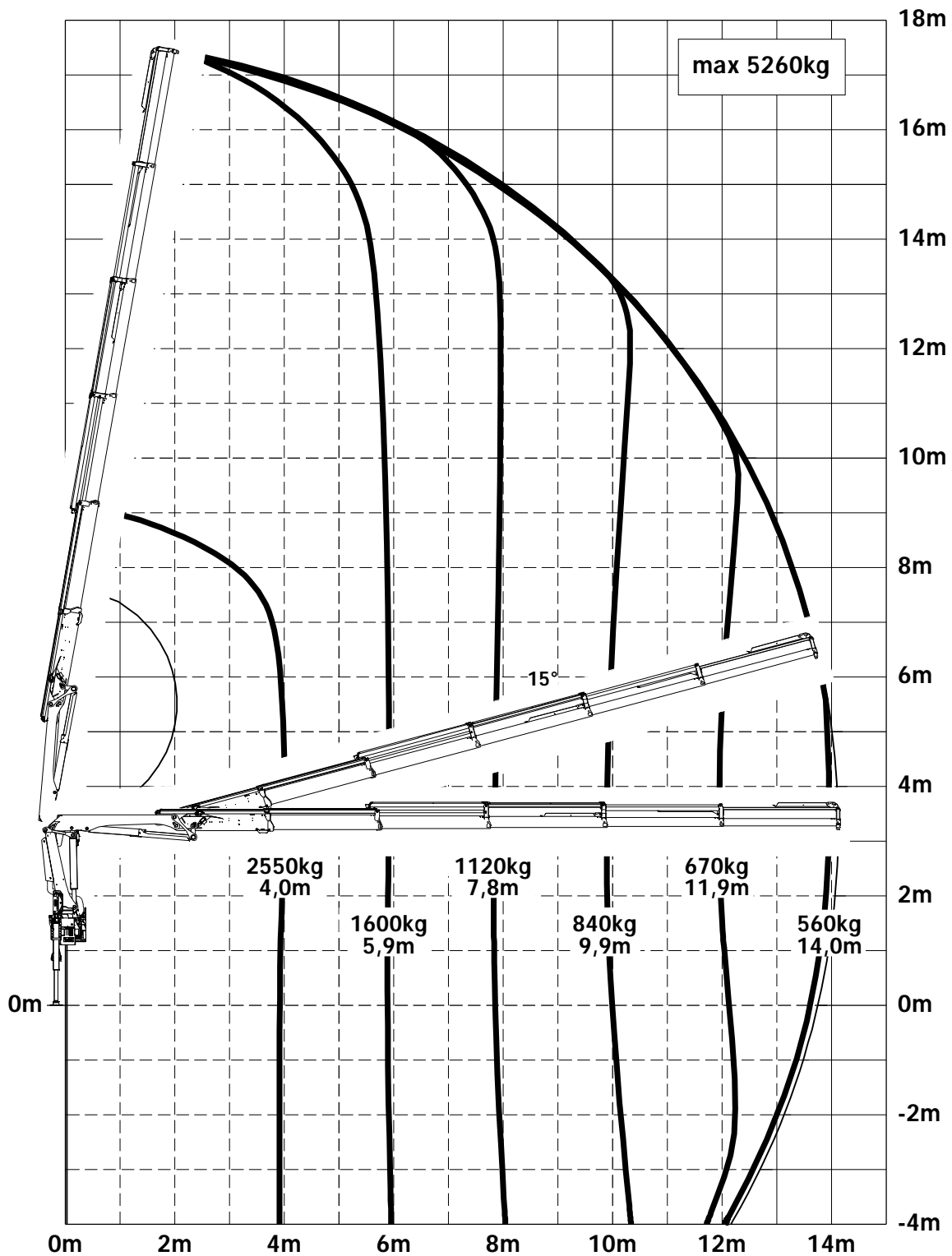

Symbolic crane figure, indications at 20° main boom position & load arm in horizontal position



For Rope winch load capacity refer to page  
Page 020.21200

Load capacity-Extension

Subject to change, production tolerances have to be taken into account.

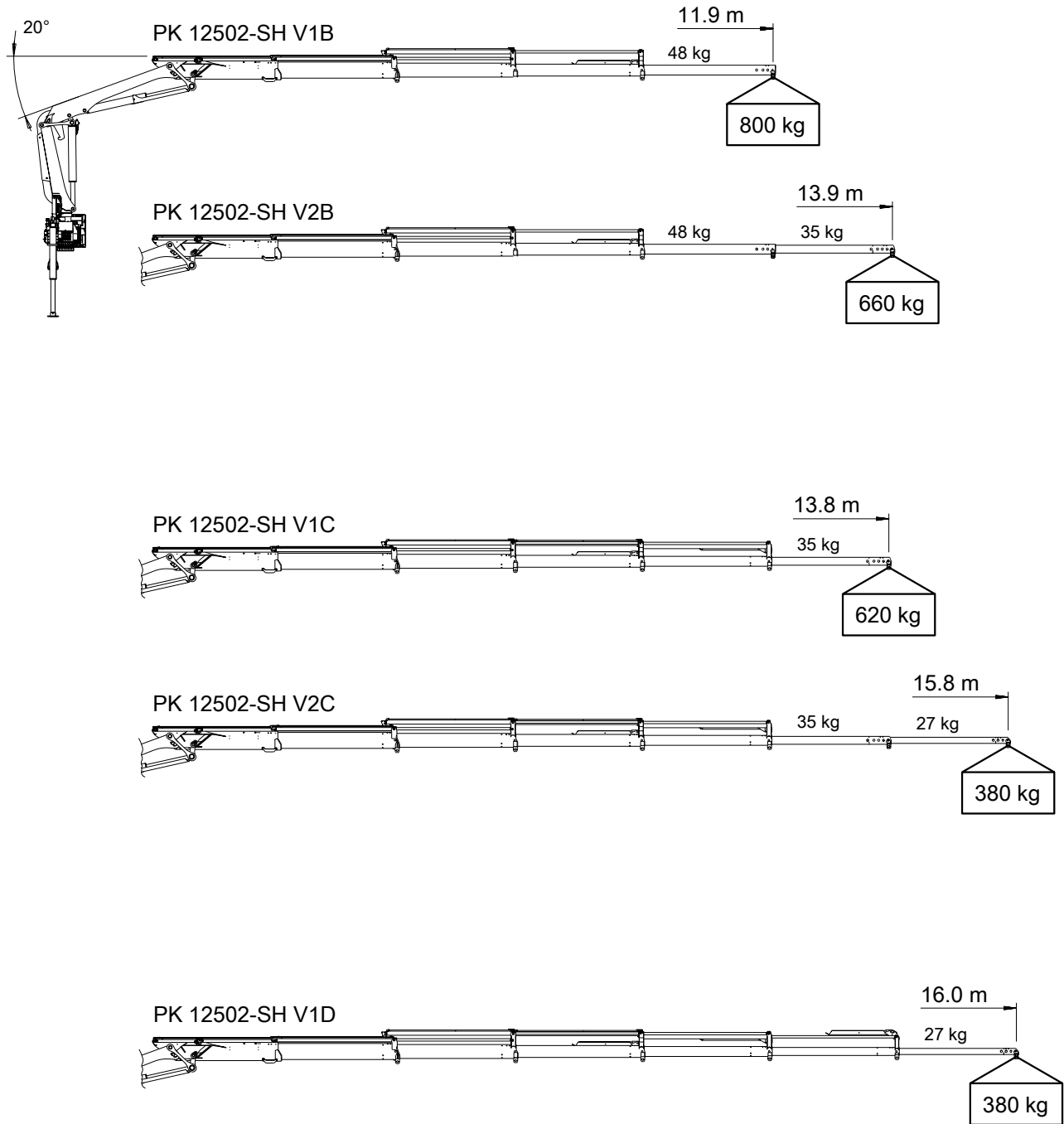

Depicted optional equipment not in all countries available.



Subject to change, production tolerances have to be taken into account.

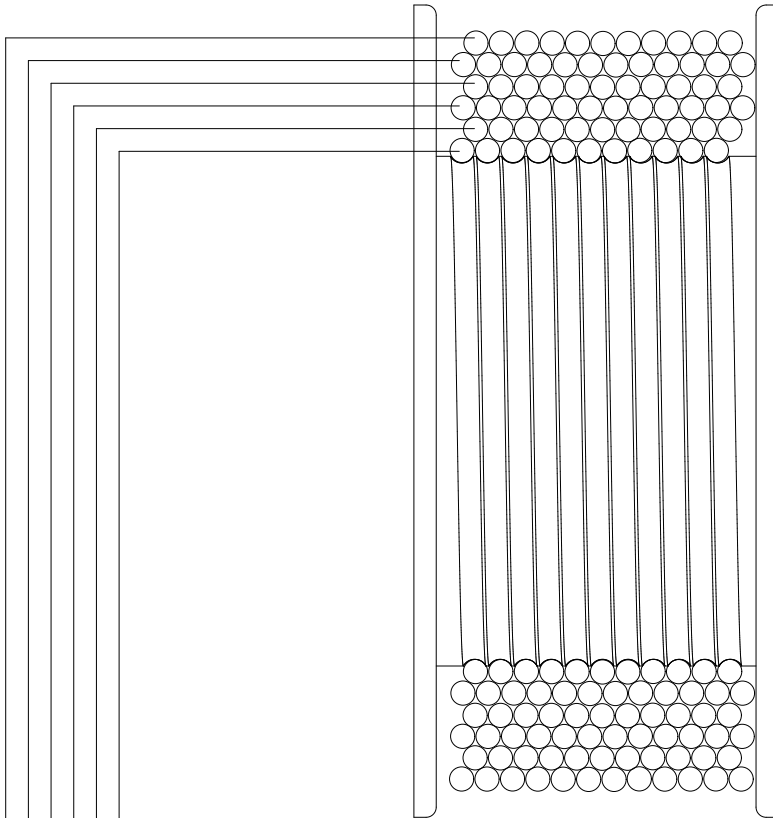

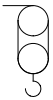
Strands		Strands	
1STRAN		2STRAN	
			
	Load capacity	Wire reception	
1	1500 kg [3,310 lb]	9,7 m [31'10"]	3000 kg [6,610 lb]
2	1400 kg [3,090 lb]	19,5 m [64'0"]	2790 kg [6,190 lb]
3	1310 kg [2,890 lb]	30,6 m [100'5"]	2620 kg [5,780 lb]
4	1230 kg [2,710 lb]	41,7 m [136'10"]	2460 kg [5,420 lb]
5	1160 kg [2,560 lb]	54,3 m [178'2"]	2320 kg [5,120 lb]
6	-	-	-

Weights of load handling devices are part of the load lifted and must be deducted from the capacity.  
Weight of the load handling equipment must be deducted from the lifting capacity.

Subject to change, production tolerances have to be taken into account.

Personal fall protection mode FPM

