

PAL Pro 43 Mechanics Truck Chevrolet 2023



6500 Regular Cab Diesel

CHEVROLET

PAL PRO 43 MECHANICS TRUCK 2023 6500 REGULAR CAB DIESEL

STOCK NUMBER: PALPRO43

NEW

AVAILABLE



OFFER INFORMATION

Location details

1118 W. Craighead Road, Charlotte, NC, 28206 -
United States 

Dealer Name

Palfinger USA

Availability

Available

Product type

New

Stock number

PALPRO43

Contact person

Rodney Allen

Dealer E-mail

r.allen@palfinger.com

Dealer phone

1-800-201-4277

\$ 169,995

Prior sale and changes reserved!

Print date: Mar 13, 2025, 10:38:16 PM

6500 Regular Cab Diesel

PAL PRO 43 MECHANICS TRUCK

- 11' long heavy-duty galvanealed steel body with double panel aluminum doors and aluminum hinges
- Master Locking System
- Gas shock door retainers on all vertically hinged doors
- (8) Recessed cargo tie-down rings
- (2) Grab handles on the rear of the body
- 14" double panel slam-type tailgate
- 21" workbench bumper with through compartment and flexible step
- 5/16" top plate bumper with integrated 2" receiver tube hitch and 7-way trailer plug
- 44" side packs with curbside 1st and 2nd compartments raised to 60" to allow for oxygen and acetylene bottles
- Sealed automotive-style wiring harness with easy access to the power distribution panel
- LED Strip lighting in all compartments
- (2) Work lights on the rear of the body with wiring harness for up to an additional (4) work lights
- Compartment interiors coated with White Zolotone coating
- Understructure and bottom of compartments undercoated
- Welder and Compressor mounting brackets on streetside compartment top
- Shelving arrangement:
 - Streetside front vertical compartment
 - Aluminum Drawer Unit dividers
 - Streetside second vertical compartment
 - (2) Adjustable divider trays (Includes (4) adjustable dividers per tray)

SERVICE CRANE TECHNICAL DETAILS**PSC8029 Telescopic Crane**

- 400-degree rotation
- 29' hydraulic reach
- 8,000 lb. maximum lift capacity (Double Line)
- Load holding valves on all cylinders
- Overload protection system
- Anti two block system located on winch in lieu of boom tip
- Radio remote control
- Power out (crane side only)/Power down outriggers
- Stabilizers on each front corner
- 30-gallon bulkhead-mounted oil reservoir

6500 Regular Cab Diesel

- Streetside horizontal compartment
 - (1) Adjustable divider tray
(Includes (4) adjustable dividers)
- Streetside rear vertical compartment
 - (2) Adjustable divider trays
(Includes (4) adjustable dividers per tray)
- Curbside front vertical compartment
 - Vented compartment with oxygen and acetylene tank holders and 60" high interior partition kit with (3) Adjustable shelves
- Curbside second vertical compartment
 - (2) Adjustable divider trays
(Includes (4) adjustable dividers per tray)
- Curbside horizontal compartment
 - (1) Adjustable divider tray
(Includes (4) adjustable dividers)
- Curbside rear vertical compartment
 - (1) Hose reel mounting shelf
- Line-X protective coating on entire front of body, compartment backs, tops, cargo floor, inside tailgate and workbench bumper

COMPRESSOR TECHNICAL DETAILS

PALFINGER PRC45V Rotary Screw Air Compressor

- 45 CFM @ 150 PSI
- 100% duty cycle
- Integrated hydraulic oil and air coolers
- High-temperature shutdown
- Cold start protection
- High-pressure relief valve

CHASSIS DETAILS

2023 Chevrolet 6500 Regular Cab Diesel 4x4

6500 Regular Cab Diesel

- 1/2" x 50' Air hose reel located in the curbside rear vertical compartment and routed through the rear wall with a guide

MECHANICS BODY

PAL Pro 43

Mechanics Bodies, Service Cranes & Compressors
Built for the Modern Work Truck.

LIFETIME EXCELLENCE





With the best equipment for the job, add a competitive edge to your business in a range of industries. Our mechanics trucks are a reliable partner in: Construction, Roadway, Railway, Agriculture, Oil & Gas, Mining, Utilities and Municipalities.



APPLICABLE CRANE MODELS

- PSC 3216
- PSC 4016
- PSC 4025
- PSC 5025
- PSC 6025
- PSC 8029

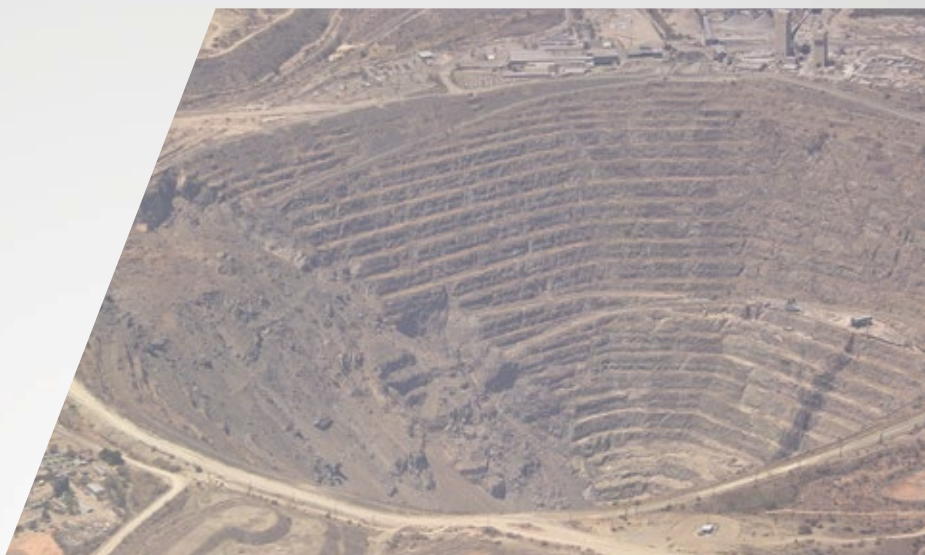

APPLICABLE COMPRESSORS

- PRC 45V
- PRC 60V



HIGHLIGHTS

The largest of the Class 3-5 PALFINGER Mechanics Bodies, the PAL Pro 43 is a steel mechanics body engineered to support our 8,000 lb 29' hydraulic service crane. Available in 11' body configurations with standard options to meet your service truck needs including bolt on mounting locations for accessories like compressors and welders, headache racks, aluminum roll out drawer units and more.

The PAL Pro 43 is manufactured with 12-gauge all A-60 galvaneal steel construction, a hybrid torsion box that eliminates frame and side pack deflection and the best rust protection in the industry.



NON-MARRING BOOM REST

Optional fixed or adjustable non-marring boom support E-coated black.

DOOR DESIGN ELIMINATE WELDING

Double panel doors with internal C-channel stiffeners, adhered with structural adhesive.

LINE-X ULTRA INTERIOR COMPARTMENT COATING FOR GREATER PROTECTION

LINE-X Ultra provides the ultimate protection for your compartment interiors. It resists the damage commonly caused by tools, chains and parts, and prevents the rust that comes as a result. As an added bonus, the coating is white in color and helps to brighten up the interior.

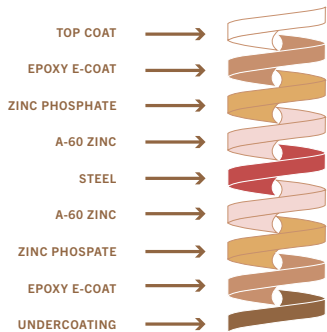

E-COAT CORROSION PROTECTION

PALFINGER's 12 step electrophoretic deposition dip process cleans the body and applies primer to the metal surfaces, ensuring complete coverage and automotive grade corrosion protection.



INTERNAL GUSSETS PREVENTS BODY CRACKING

Every raised compartment comes with PALFINGER's engineered gussets for increased protection against the body cracking in the door corner.

WORK BENCH BUILT FOR YOUR HARD WORK

A true mechanics work bench, featuring a 21" work bench bumper, receiver hitch, 5/16" steel top plate and thru compartment for additional storage.

FEATURES



HYBRID TORSION BOX BUILT FOR CRANES

Designed from the start for crane applications and utilizing 10ga A-60 galvaneal steel, the hybrid torsion box eliminates truck frame twist and side pack deflection.

STRUCTURAL CROSS-MEMBERS PAYLOAD SUPPORT

Tubular 3" x 5" structural steel cross-members interlace the torsion box to support compartment loads.

OUTRIGGER HOUSING INTEGRATED LIFTING SUPPORT

Integrated outrigger tube reduces stress on chassis frame by transferring the crane load directly to the ground.

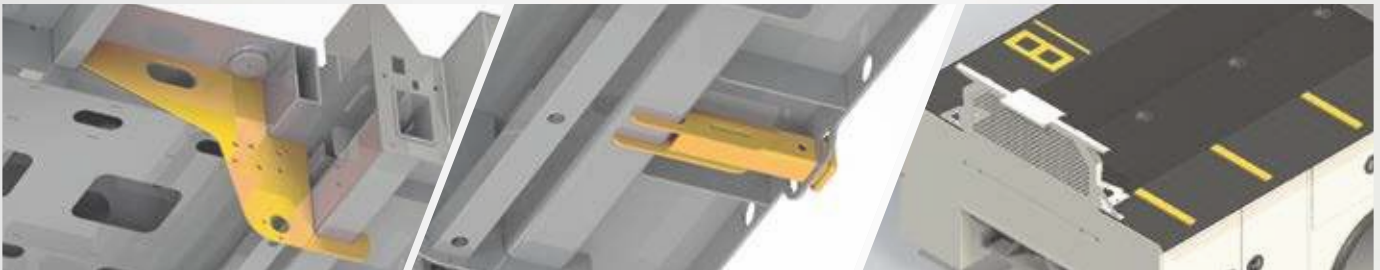

REAR SHEAR PLATE BODY MOUNTS SECURE AND SUPPORTIVE MOUNTING

Steel plates prevent lateral body shift on chassis, providing additional support for crane loads.

INTEGRATED HITCH RECEIVER CLASS 5 RECEIVER

2" I.D. receiver tube, attached directly to body structure. 16,000 lbs towing capacity.

THREADED WELDMENT OPTIONS TO PROTECT YOUR BODY

Boom rest, welder, compressor, EnPak, Air-n-Arc and AirPak mounts are available from the factory to eliminate the need to drill holes in the body.



STEEL SHELVING AND DIVIDER TRAYS FLEXIBLE STORAGE

Steel shelves or divider trays with 250 lb rated capacity offer variable storage options for each compartment.

HEADACHE RACK SAVES COSTLY REPAIRS

This light bar bracket with a punched screen prevents cargo area contents from making contact with the rear window of the cab-saving you from costly rear window repairs & cleanup.

BOLT ON HANDRAIL OPTION FOR ADDED SAFETY

Ergonomically designed handrail option, with a stable surface to grip, for your added security against tripping or slipping hazards.

STANDARD CONFIGURATIONS

43-11

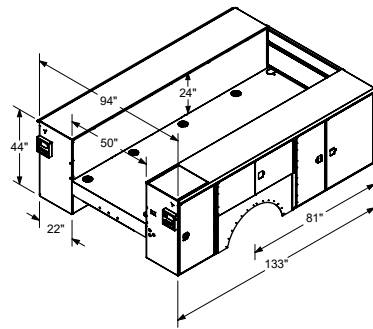

11' standard configuration
 44" tall compartment heights
 14" tall one handed tailgate
 Treadplate compartment top overlays

43-11CS

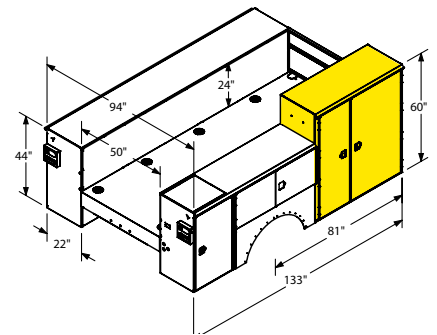

11' CS raised
 44" tall compartment heights
 CS front compartments raised to 60"
 14" tall one handed tailgate
 Treadplate compartment top overlays
 Reinforced raised compartment

43-11SS

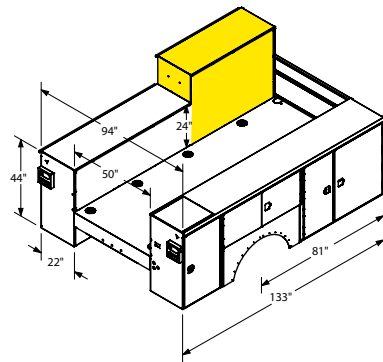

11' SS raised
 44" tall compartment heights
 SS front compartments raised to 60"
 14" tall one handed tailgate
 Treadplate compartment top overlays
 Reinforced raised compartment

43-11SSCS

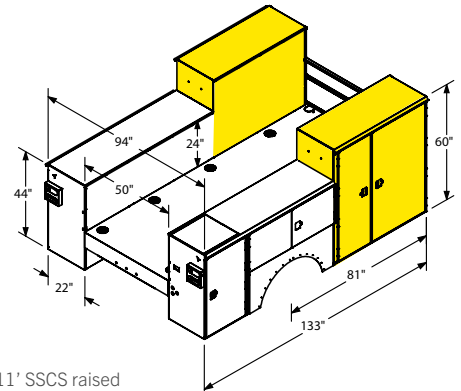

11' SCS raised
 44" tall compartment heights
 SS & CS front compartments raised to 60"
 14" tall one handed tailgate
 Treadplate compartment top overlays
 Reinforced raised compartments

43-11SS60CS

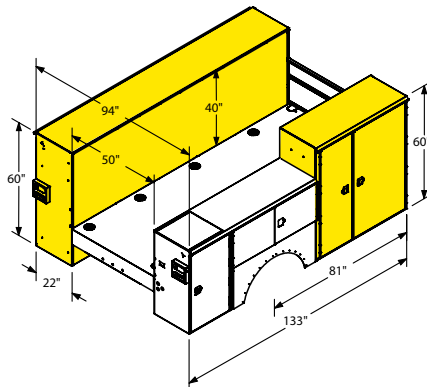

11' SS60CS raised
 44" tall compartment heights
 SS all compartments raised to 60"
 CS front compartments raised to 60"
 14" tall one handed tailgate
 Treadplate compartment top overlays
 Reinforced raised compartments

SERVICE CRANE

PRODUCT RANGE

TECHNICAL SPECIFICATIONS

MODEL	CAPACITY	RATED LIFTING MOMENT	MAX LIFTING MOMENT	BOOM EXTENSIONS	BOOM LENGTH	WINCH SPEED	STANDARD WEIGHT	CHASSIS SPECIFICATION
PSC 3216 E	4,000 lbs. (1,814 kg)	12,500 ft*lbs. (17 kNm (1.7 mt))	14,560 ft*lbs. (19.6 kNm (2 mt))	1 Hydraulic + 1 Manual (2 Hydraulic Option)	16 ft. (4.9 m)	21.2 ft./min (6.46 m/min)	650 lbs. (295 kg)	Class 3
PSC 3216 H	4,000 lbs. (1,814 kg)	12,500 ft*lbs. (17 kNm (1.7 mt))	14,560 ft*lbs. (19.6 kNm (2 mt))	1 Hydraulic + 1 Manual (2 Hydraulic Option)	16 ft. (4.9 m)	29.7 ft./min (9.05 m/min)	630 lbs. (286 kg)	Class 3
PSC 4016 E	4,000 lbs. (1,814 kg)	18,500 ft*lbs. (25.1 kNm (2.6 mt))	23,235 ft*lbs. (31.4 kNm (3.2 mt))	1 Hydraulic + 1 Manual (2 Hydraulic Option)	16 ft. (4.9 m)	21.2 ft./min (6.46 m/min)	650 lbs. (295 kg)	Class 3
PSC 4016 H	4,000 lbs. (1,814 kg)	18,500 ft*lbs. (25.1 kNm (2.6 mt))	23,235 ft*lbs. (31.4 kNm (3.2 mt))	1 Hydraulic + 1 Manual (2 Hydraulic Option)	16 ft. (4.9 m)	29.7 ft./min (9.05 m/min)	630 lbs. (286 kg)	Class 3
PSC 4025 E	4,000 lbs. (1,814 kg)	18,500 ft*lbs. (25.1 kNm (2.6 mt))	20,585 ft*lbs. (27.9 kNm (2.9 mt))	2 Hydraulic	25 ft. (7.6 m)	21.2 ft./min (6.46 m/min)	1,010 lbs. (458 kg)	Class 3
PSC 4025 H	4,000 lbs. (1,814 kg)	18,500 ft*lbs. (25.1 kNm (2.6 mt))	20,585 ft*lbs. (27.9 kNm (2.9 mt))	2 Hydraulic	25 ft. (7.6 m)	29.7 ft./min (9.05 m/min)	995 lbs. (451 kg)	Class 3
PSC 5025 E	5,000 lbs. (2,268 kg)	32,500 ft*lbs. (44.2 kNm (4.5 mt))	36,360 ft*lbs. (49.3 kNm (5 mt))	2 Hydraulic	25 ft. (7.6 m)	18.8 ft./min (5.73 m/min)	1,170 lbs. (530 kg)	Class 4
PSC 5025 H	5,000 lbs. (2,268 kg)	32,500 ft*lbs. (44.2 kNm (4.5 mt))	36,360 ft*lbs. (49.3 kNm (5 mt))	2 Hydraulic	25 ft. (7.6 m)	56 ft./min (17.07 m/min)	1,155 lbs. (525 kg)	Class 4
PSC 6025 E	6,000 lbs. (2,750 kg)	38,500 ft*lbs. (52.2 kNm (5.3 mt))	42,800 ft*lbs. (58.0 kNm (5.9 mt))	2 Hydraulic	25 ft. (7.6 m)	43.3 ft./min (13.20 m/min)	1,280 lbs. (580 kg)	Class 4
PSC 6025 H	6,000 lbs. (2,750 kg)	38,500 ft*lbs. (52.2 kNm (5.3 mt))	42,800 ft*lbs. (58.0 kNm (5.9 mt))	2 Hydraulic	25 ft. (7.6 m)	51 ft./min (15.54 m/min)	1,230 lbs. (560 kg)	Class 4
PSC 8029 H	8,000 lbs. (3,650 kg)	43,000 ft*lbs. (58.3 kNm (5.9 mt))	49,180 ft*lbs. (66.5 kNm (6.8 mt))	2 Hydraulic	29 ft. (8.9 m)	60 ft./min (18.28 m/min)	2,149 lbs. (975 kg)	Class 5
PSC 10829 H	10,800 lbs. (4,900 kg)	62,000 ft*lbs. (84.1 kNm (8.6 mt))	68,900 ft*lbs. (93.2 kNm (9.5 mt))	2 Hydraulic	29 ft. (8.9 m)	60 ft./min (18.28 m/min)	2,407 lbs. (1,092 kg)	Class 6
PSC 12529 H	12,500 lbs. (5,700 kg)	72,000 ft*lbs. (97.6 kNm (10 mt))	79,450 ft*lbs. (107.7 kNm (11 mt))	2 Hydraulic	29 ft. (8.9 m)	60 ft./min (18.28 m/min)	2,731 lbs. (1,239 kg)	Class 6
PSC 14029 H	14,000 lbs. (6,400 kg)	86,000 ft*lbs. (116.6 kNm (11.9 mt))	94,676 ft*lbs. (128.4 kNm (13 mt))	2 Hydraulic	29 ft. (8.9 m)	60 ft./min (18.28 m/min)	2,833 lbs. (1,285 kg)	Class 7



OSP_PALPRO43_06/20

Cranes shown in the leaflet are partially optional equipped and do not always correspond to the standard version. All PSC models are subject to change as PALFINGER updates, improves, and technologically advances their cranes and the industry.

OMAHA STANDARD PALFINGER
 3501 S. 11th Street | Council Bluffs, IA
 51501-0876 | USA
 T + 1 800 279 2201
 info@palfingerna.com

PALFINGER.COM

HYDRAULIC SERVICE CRANE PSC 8029

LIGHTER | LONGER | STRONGER

LIFETIME EXCELLENCE



BUILT TO LAST

Meeting or exceeding all ASME and OSHA standards, the PSC 8029 is a full hydraulic service crane with 8,000 lbs capacity. The PSC 8029 hydraulic service crane comes standard with simultaneous multi-function proportional radio remote controls, superior weight-to-lift ratios, and 29' of reach. The crane is exclusively E-coated by PALFINGER for the best rust protection in the industry.



E-COAT PROTECTION

Most rust resistant telescopic crane on the market



MEDIA BLAST

A high quality process that removes any surface imperfections and provides an optimized surface for E-coating.

E-COAT

Automotive grade and environmentally friendly coating process is applied with precision over the entire product ensuring superior corrosion protection.

TOP COAT

All E-coated steel components receive a top coat finish that ensures maximum durability.



LIGHTER.

PALFINGER's service cranes are as much as **30% lighter** than the competition — without sacrificing strength or reach. Less weight means more payload for tools and supplies necessary on the job site.



LONGER.

Up to **30% longer** than the competition, PALFINGER's service cranes have the longest reach in the industry. More reach means fewer setup adjustments on the job site and improved access for those challenging lifts. Standard boom lengths are 16', 25', and 29' depending on the size of the crane.



STRONGER.

PALFINGER's service cranes are up to **20% stronger** than the competition, with a superior lifting moment rating and load chart to do more work in more places. With PALFINGER's safety systems, including the exclusive winch damage prevention system, lifting more is also safer than ever before.

STANDARD FEATURES

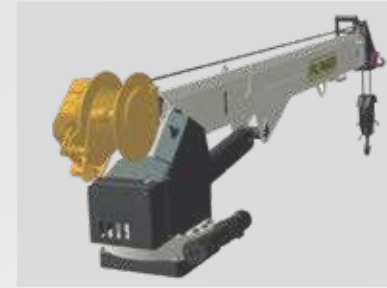

PLANETARY WINCH

Planetary winch provides speed and durability.



HORSE HEAD

Low profile design. Optional boom tip hook and lights. No A2B components to interfere with operation.



LOAD BLOCK STOWING BRACKET

Bracket and pads designed to keep load block from contacting the boom when stowed.

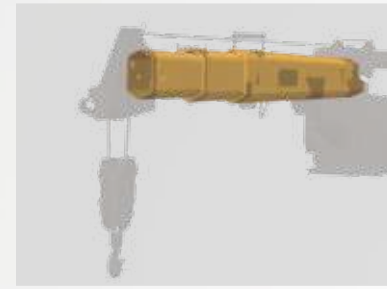

HEXAGONAL BOOMS

Ultra-low maintenance high tensile strength self-centering single weld boom sections powered by internal extension cylinders.



CYLINDERS

Internal extension cylinders for 29' of hydraulically powered outreach. All cylinders are E-coated and use a 5 stage marine grade seal system.



CONTROL SYSTEM

Features a standard proportional wireless remote control unit, integrated E-stop button, warning horn and manual valve activation capability. Cranes are controlled with 12V DC power supply.



3RD WRAP LIMITING SYSTEM

Integrated system prevents wire rope spool off, ensuring three wraps remain on drum. Exceeds ASME B30.5.



PROPORTIONAL CONTROL

Through the control valve, fully proportional control of all functions is standard.



3-YEAR WARRANTY

PALFINGER service cranes come with an industry leading 3-year warranty on all structural components

OPTIONS & ACCESSORIES

Many optional features are available for PALFINGER service cranes to meet your demands on the job. Contact your PALFINGER Representative to learn more!

PERSONNEL BASKET CRANE ACCESSORY (PATENT PENDING)

Industry-first from PALFINGER designed specifically for service cranes with 5,000 lbs. capacity and above. Quickly set up and attach basket to crane for maximum efficiency on the job. Folds into a compact storage box and mounts onto the body for transport.

Personnel Basket Capacity	300 lbs.
Personnel Basket Weight	280 lbs.
Complete Installation (incl. boxes):	400 lbs.



OPTIONS & ACCESSORIES



BOOM TIP HOOK
PALFINGER exclusive 2.5 ton capacity boom tip hook. Horsehead has threaded weldment for mounting.



ELS SYSTEM EASY LOWERING OF LOAD BLOCK
Unique solution to lower the hooking point for the load block. Winch is used to lift load block in its stowed position.



BOOM TIP LIGHTING
With the addition of a retractable cord reel we bring power to the boom tip to light dual work lights that swing freely while raising and lowering the boom to illuminate your working area.



BOOM REST
Non-marring boom rest that supports the crane while protecting the paint finish.



OUTRIGGERS FOR ADDED STABILITY
Support your lifting application needs with manual and hydraulic outrigger options.



P2 RADIO REMOTE CONTROL
Paddle-style controller offers the possibility to completely eliminate the radio signal when the cord is plugged into the receiver.



PROTECTIVE CASE WITH BELT LOOP KEEPS REMOTE AT YOUR SIDE
Nylon case with clear plastic cover protects your remote control from harsh weather elements, while the belt loop allows you to attach the remote to your work belt for added convenience on the job.



SILICONE COVER FOR REMOTE KEEPS REMOTE CLEAN
Flexible silicone cover helps keep dust, dirt, and grime off of your remote control – so you can focus on controlling your service crane and not cleaning the remote.



REMOTE STORAGE BRACKET SECURELY STOWS REMOTE
Stow the remote control using the metal storage bracket and mount it in the cab or the crane compartment. Thanks to the remote magnet, the remote will be held securely in place during transport.



TECHNICAL SPECIFICATIONS

WINCH DAMAGE PREVENTION SYSTEM

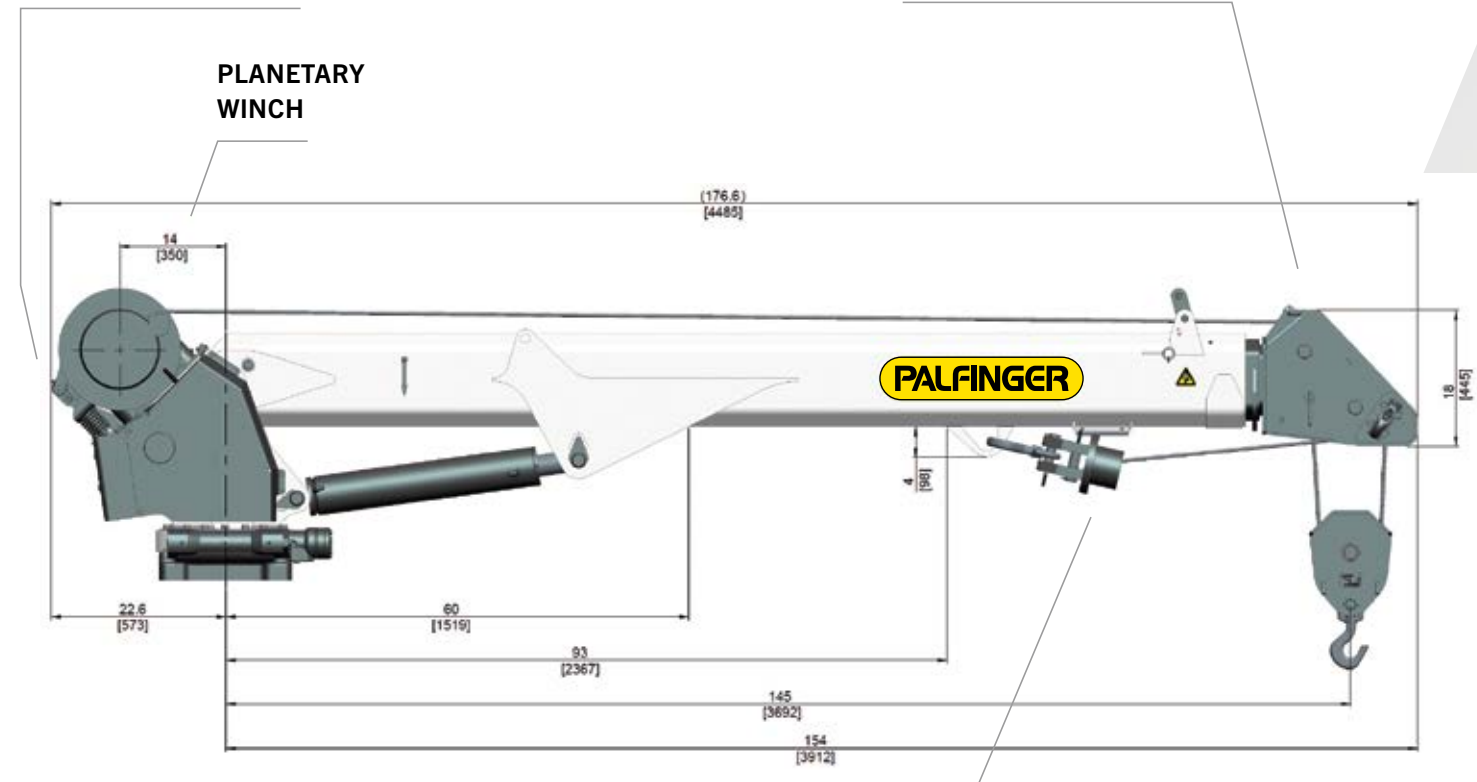

LOAD BLOCK STOWING BRACKET

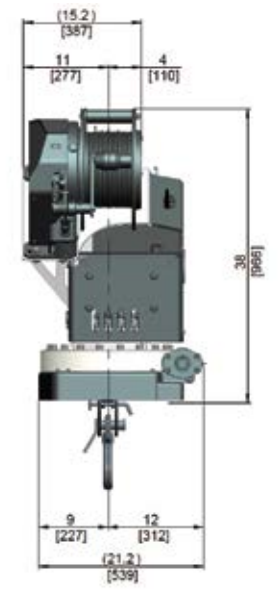

LOAD CHART

CRANE RATING

Rated lifting moment	43,000 ft*lbs. (58.3 kNm (5.9 mt))
Maximum lifting moment	49,180 ft*lbs. (66.5 kNm (6.8 mt))
Boom extensions	29 ft. (8.9 m)
2 hydraulic	
Crane weight	2,149 lbs. (975 kg)
Hydraulically powered extensions	

CONTROL SYSTEM

Wireless remote control unit	
Integrated E-stop button	
Manual emergency valve activation capability	
Integrated warning horn	
12V DC power supply	

ROTATION SYSTEM

Slewing torque	4,920 ft*lbs. (6.8 kNm (0.7 mt))
Slewing angle	400° rotation
Worm gear drive with surface hardened gear teeth	

STANDARDS (meets or exceeds)

Crane design	ASME B30.5	OSHA 1910.28
Calculation	EN 12999 H1, B6	

PLANETARY GEAR WINCH

Max. winch force single line	4,000 lbs. (1,820 kg)
Max. winch force double line	8,000 lbs. (3,650 kg)
Max. line speed	60 ft./min (18.2 m/min)
Cable size and length	7/16" x 120' (11 mm x 36.5 m)
Two-block damage prevention system	
3rd wrap end stop system	

HYDRAULIC SYSTEM

Operating pressure	3,045 psi (21 Mpa (210 bar))
Required oil flow	8-12 GPM (30-45 l/min)
Electronic overload protection system	
Five stage marine-grade seals on all cylinders	
Non integrated load-holding valves on all cylinders	

CRANE | CHASSIS INTERFACE

Base plate dimension	17.75" x 17.75" (450 mm x 450 mm)
Hole pattern	14.75" x 14.75" (375 mm x 375 mm)
Mounting bolts	4 x 1 1/4" -12 UNF

CHASSIS RECOMMENDATION

Chassis style	Conventional
Minimum GVWR	Class 5 (19,500 lbs. (8,845 kg))

Weights of load-handling devices are part of the load lifted and must be deducted from the capacity.

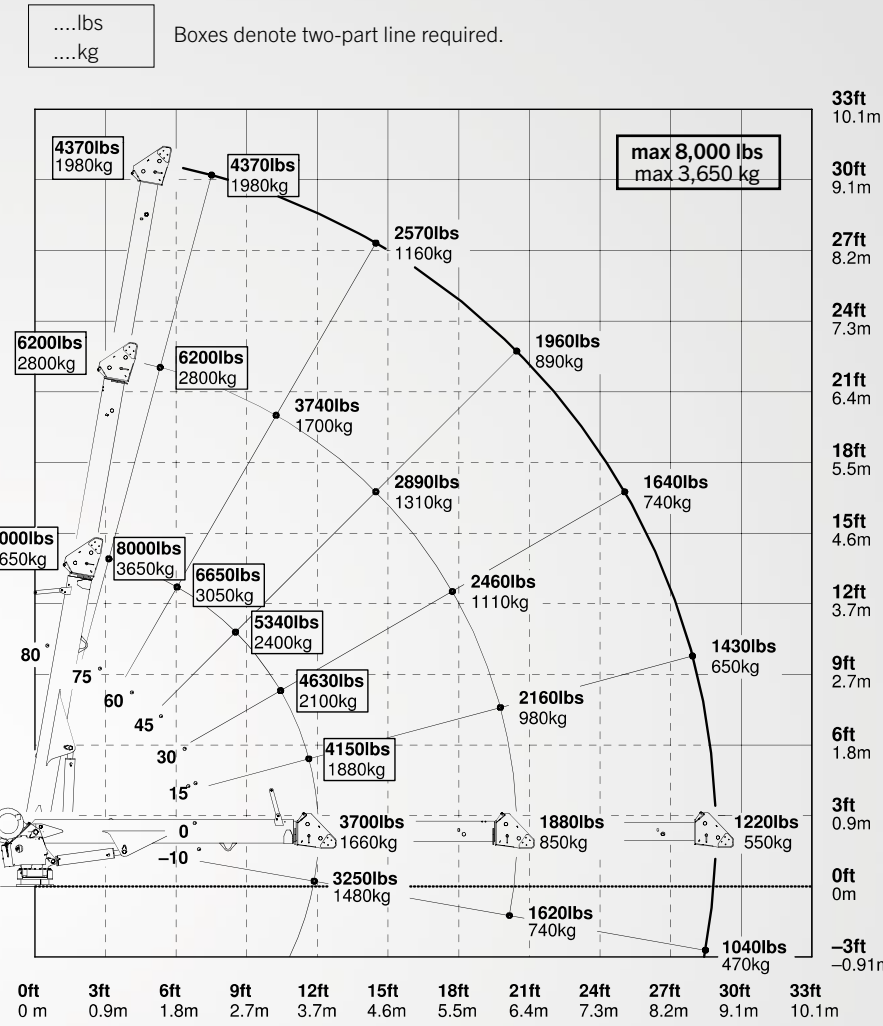

PRODUCT RANGE

TECHNICAL SPECIFICATIONS

MODEL	CAPACITY	RATED LIFTING MOMENT	MAX LIFTING MOMENT	BOOM EXTENSIONS	BOOM LENGTH	WINCH SPEED	STANDARD WEIGHT	CHASSIS SPECIFICATION
PSC 3216 E	4,000 lbs. (1,814 kg)	12,500 ft*lbs. (17 kNm (1.7 mt))	14,560 ft*lbs. (19.6 kNm (2 mt))	1 Hydraulic + 1 Manual (2 Hydraulic Option)	16 ft. (4.9 m)	21.2 ft./min (6.46 m/min)	650 lbs. (295 kg)	Class 3
PSC 3216 H	4,000 lbs. (1,814 kg)	12,500 ft*lbs. (17 kNm (1.7 mt))	14,560 ft*lbs. (19.6 kNm (2 mt))	1 Hydraulic + 1 Manual (2 Hydraulic Option)	16 ft. (4.9 m)	29.7 ft./min (9.05 m/min)	630 lbs. (286 kg)	Class 3
PSC 4016 E	4,000 lbs. (1,814 kg)	18,500 ft*lbs. (25.1 kNm (2.6 mt))	23,235 ft*lbs. (31.4 kNm (3.2 mt))	1 Hydraulic + 1 Manual (2 Hydraulic Option)	16 ft. (4.9 m)	21.2 ft./min (6.46 m/min)	650 lbs. (295 kg)	Class 3
PSC 4016 H	4,000 lbs. (1,814 kg)	18,500 ft*lbs. (25.1 kNm (2.6 mt))	23,235 ft*lbs. (31.4 kNm (3.2 mt))	1 Hydraulic + 1 Manual (2 Hydraulic Option)	16 ft. (4.9 m)	29.7 ft./min (9.05 m/min)	630 lbs. (286 kg)	Class 3
PSC 4025 E	4,000 lbs. (1,814 kg)	18,500 ft*lbs. (25.1 kNm (2.6 mt))	20,585 ft*lbs. (27.9 kNm (2.9 mt))	2 Hydraulic	25 ft. (7.6 m)	21.2 ft./min (6.46 m/min)	1,010 lbs. (458 kg)	Class 3
PSC 4025 H	4,000 lbs. (1,814 kg)	18,500 ft*lbs. (25.1 kNm (2.6 mt))	20,585 ft*lbs. (27.9 kNm (2.9 mt))	2 Hydraulic	25 ft. (7.6 m)	29.7 ft./min (9.05 m/min)	995 lbs. (451 kg)	Class 3
PSC 5025 E	5,000 lbs. (2,268 kg)	32,500 ft*lbs. (44.2 kNm (4.5 mt))	36,360 ft*lbs. (49.3 kNm (5 mt))	2 Hydraulic	25 ft. (7.6 m)	18.8 ft./min (5.73 m/min)	1,170 lbs. (530 kg)	Class 4
PSC 5025 H	5,000 lbs. (2,268 kg)	32,500 ft*lbs. (44.2 kNm (4.5 mt))	36,360 ft*lbs. (49.3 kNm (5 mt))	2 Hydraulic	25 ft. (7.6 m)	56 ft./min (17.07 m/min)	1,155 lbs. (525 kg)	Class 4
PSC 6025 E	6,000 lbs. (2,750 kg)	38,500 ft*lbs. (52.2 kNm (5.3 mt))	42,800 ft*lbs. (58.0 kNm (5.9 mt))	2 Hydraulic	25 ft. (7.6 m)	43.3 ft./min (13.20 m/min)	1,280 lbs. (580 kg)	Class 4
PSC 6025 H	6,000 lbs. (2,750 kg)	38,500 ft*lbs. (52.2 kNm (5.3 mt))	42,800 ft*lbs. (58.0 kNm (5.9 mt))	2 Hydraulic	25 ft. (7.6 m)	51 ft./min (15.54 m/min)	1,230 lbs. (560 kg)	Class 4
PSC 8029 H	8,000 lbs. (3,650 kg)	43,000 ft*lbs. (58.3 kNm (5.9 mt))	49,180 ft*lbs. (66.5 kNm (6.8 mt))	2 Hydraulic	29 ft. (8.9 m)	60 ft./min (18.28 m/min)	2,149 lbs. (975 kg)	Class 5
PSC 10829 H	10,800 lbs. (4,900 kg)	62,000 ft*lbs. (84.1 kNm (8.6 mt))	68,900 ft*lbs. (93.2 kNm (9.5 mt))	2 Hydraulic	29 ft. (8.9 m)	60 ft. /min (18.28 m/min)	2,407 lbs. (1,092 kg)	Class 6
PSC 12529 H	12,500 lbs. (5,700 kg)	72,000 ft*lbs. (97.6 kNm (10 mt))	79,450 ft*lbs. (107.7 kNm (11 mt))	2 Hydraulic	29 ft. (8.9 m)	60 ft./min (18.28 m/min)	2,731 lbs. (1,239 kg)	Class 6
PSC 14029 H	14,000 lbs. (6,400 kg)	86,000 ft*lbs. (116.6 kNm (11.9 mt))	94,676 ft*lbs. (128.4 kNm (13 mt))	2 Hydraulic	29 ft. (8.9 m)	60 ft. /min (18.28 m/min)	2,833 lbs. (1,285 kg)	Class 7



PROUDLY ASSEMBLED
in the USA

OSP-PSC8029 | 06/20

Cranes shown in the leaflet are partially optional equipped and do not always correspond to the standard version. All PSC models are subject to change as PALFINGER updates, improves, and technologically advances their cranes and the industry.

OMAHA STANDARD PALFINGER
3501 S. 11th Street | Council Bluffs, IA
51501-0876 | USA
T + 1 800 279 2201
info@palfingerna.com

PALFINGER.COM